

KENWOOD

AUDIO VIDEO SURROUND RECEIVER

KR-V5580

INSTRUCTION MANUAL

KENWOOD CORPORATION

Before applying power

Caution: Read this page carefully to ensure safe operation.

KR-V5580 (En)

Units are designed for operation as follows.

2 U.S.A. and Canada AC 120 V only
Australia AC 240 V only

Europe and U.K. AC 230 V only
China AC 220 V only
*Other countries AC 110-120 / 220 / 230-240 V switchable

For other countries

*AC voltage selection

This unit operates on 110 - 120 volts or 220 - 240 volts AC. The AC voltage selector switch on the rear panel is set to the voltage that prevails in the area to which the unit is shipped. Before connecting the power cord to your AC outlet, make sure that the setting position of this switch matches your line voltage. If not, it must be set to your voltage in accordance with the following direction.

Note

Our warranty does not cover damage caused by excessive line voltage due to improper setting of the AC voltage selector switch.



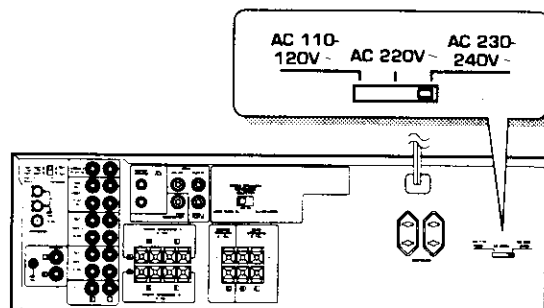

AC voltage Selector switch







Move switch lever to match your line voltage with a small screwdriver or other pointed tool.

Safety precautions

WARNING : TO PREVENT FIRE OR ELECTRIC SHOCK, DO NOT EXPOSE THIS APPLIANCE TO RAIN OR MOISTURE.

 <div data-bbox="365 1052 578 1129" style="border: 1px solid black; padding: 2px; text-align: center;"> CAUTION <small>RISK OF ELECTRIC SHOCK DO NOT OPEN</small> </div> 	<p>CAUTION TO REDUCE THE RISK OF ELECTRIC SHOCK, DO NOT REMOVE COVER (OR BACK) NO USER-SERVICEABLE PARTS INSIDE, REFER SERVICING TO QUALIFIED SERVICE PERSONNEL</p>
	<p>THE LIGHTNING FLASH WITH ARROWHEAD SYMBOL, WITHIN AN EQUILATERAL TRIANGLE, IS INTENDED TO ALERT THE USER TO THE PRESENCE OF UNINSULATED "DANGEROUS VOLTAGE" WITHIN THE PRODUCT'S ENCLOSURE THAT MAY BE OF SUFFICIENT MAGNITUDE TO CONSTITUTE A RISK OF ELECTRIC SHOCK TO PERSONS.</p>
	<p>THE EXCLAMATION POINT WITHIN AN EQUILATERAL TRIANGLE IS INTENDED TO ALERT THE USER TO THE PRESENCE OF IMPORTANT OPERATING AND MAINTENANCE (SERVICING) INSTRUCTIONS IN THE LITERATURE ACCOMPANYING THE APPLIANCE.</p>

AVERTISSEMENT : POUR EVITER TOUT INCENDIE OU CHOC ELECTRIQUE, NE PAS EXPOSER CET APPAREIL A LA PLUIE OU A L'HUMIDITE.

 <div data-bbox="360 1602 573 1680" style="border: 1px solid black; padding: 2px; text-align: center;"> ATTENTION <small>RISQUE DE CHOC ELECTRIQUE EN PAS OUVRIR</small> </div> 	<p>ATTENTION POUR REDUIRE LES RISQUES DE CHOC ELECTRIQUE, NE PAS DEPOSER LE COUVERCLE (OU LE PANNEAU ARRIERE). AUCUNE PIECE REPARABLE PAR L'UTILISATEUR NE SE TROUVE A L'INTERIEUR. CONFIER TOUT TRAVAIL D'ENTRETIEN A UN PERSONNEL DE SERVICE QUALIFIE.</p>
	<p>LE SYMBOLE DE L'ECLAIR DANS UN TRIANGLE EQUILATERAL A POUR BUT D'ATTIRER L'ATTENTION DE L'UTILISATEUR SUR LA PRESENCE, A L'INTERIEUR DU COFFRET, D'UNE TENSION DANGEREUSE ET NON ISOLEE D'UNE PUISSANCE SUFFISANTE POUR CONSTITUER UN RISQUE DE COMMOTION ELECTRIQUE AUX ETRES HUMAINS.</p>
	<p>LE POINT D'EXCLAMATION DANS UN TRIANGLE EQUILATERAL A POUR BUT D'ATTIRER L'ATTENTION DE L'UTILISATEUR SUR LA PRESENCE, DANS LA LITTERATURE QUI ACCOMPAGNE CET APPAREIL, D'INFORMATIONS IMPORTANTES RELATIVE A L'EXPLOITATION ET A L'ENTRETIEN.</p>

Special features

DOLBY PRO LOGIC & DOLBY 3 STEREO

The surround system reproduces video software program carrying the  mark with similar acoustic effects to movie theaters.

The DOLBY PRO LOGIC mode controls the audio signals of the Front Left/Right, Center and Rear surround channels using the built-in directivity enhancer circuit to reproduce the feeling of sound motions realistically.





The DOLBY 3 STEREO mode can reproduce the motions of sound even when only the front and center speakers are used, by providing proper acoustic position using the directivity enhancer circuit.

Unpacking

Unpack the unit carefully and make sure that all accessories are put aside so they will not be lost. Examine the unit for any possibility of shipping damage. If your unit is damaged or fails to operate, notify your dealer immediately. If your unit was shipped to you directly, notify the shipping company without delay. Only the consignee (the person or company receiving the unit) can file a claim against the carrier for shipping damage.

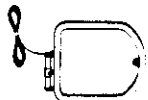
We recommend that you retain the original carton and packing materials for use should you transport or ship the unit in the future.

Accessories

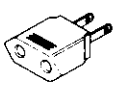
<p>FM indoor antenna (1)</p> 	<p>AM loop antenna (1)</p> 	<p>Loop antenna stand (1)</p> 
<p>Remote control unit (1)</p> 	<p>Batteries (R6/AA) (2)</p> 	<p>* AC plug adaptor (1)</p> 

* Use to adapt the plug on the power cord to the shape of the wall outlet. (Accessory only for regions where use is necessary.)

Contents

Caution : Read the pages marked  carefully to ensure safe operation.

Before applying power	↑ Before applying power	2
	↑ Safety precautions	2
Special features		3
IMPORTANT SAFEGUARDS		4
System connections		6
	About the system control connections	7
	FM DE-EMPHASIS/CHANNEL SPACE switch	9
Controls and indicators		10
Operation of remote control unit		12
Playing music		13
Sound adjustment functions		14
Recording		16
	To record a music source	16
	Copying tape (Tape dubbing)	16
Broadcast reception		17
	Receiving broadcast stations	17
	Receiving radio stations by specifying its frequency	18
	Storing radio stations in memory (Station preset)	19
	Receiving a preset station	19
	Receiving all preset stations in order	19
Operation of video components		20
	Playback of videotape	20
	Recording of video source	20
Presence play		21
	DOLBY PRO LOGIC surround arrangement	22
	DOLBY PRO LOGIC surround playback	23
	DOLBY 3 STEREO adjustment and playback	24
In case of difficulty		26
Specifications		27

Please read all of the safety and operating instructions before operating this appliance. Adhere to all warnings on the appliance and in the instruction manual. Follow all the safety and operating instructions. These safety and operating instructions should be retained for future reference.

- 1. Power sources** – The appliance should be connected to a power supply only of the type described in the instruction manual or as marked on the appliance. If you are not sure of the type of power supply to your home, consult your appliance dealer or local power company. For appliances intended to operate from battery power, or other sources, refer to the instruction manual.
- 2. Power-cord protection** – Power-supply cords should be routed so that they are not likely to be walked on or pinched by items placed upon or against them, pay particular attention to cords at plugs, convenience receptacles, and the point where they exit from the appliance.

Never pull or stretch the cord.

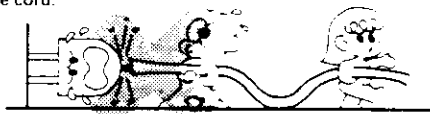

- 3. CAUTION – Polarization** – This appliance may be equipped with a polarized alternating-current line plug (a plug having one blade wider than the other). This plug will fit into the power outlet only one way. This is a safety feature. If you are unable to insert the plug fully into the outlet, try reversing the plug. If the plug should still fail to fit, contact your electrician to replace your obsolete outlet. Do not defeat the safety purpose of the polarized plug.

- 4. Ventilation** – Slots and openings in the cabinet are provided for ventilation and to ensure reliable operation of the appliance and to protect it from overheating, and these openings must not be blocked or covered. The appliance should be situated so that its location or position does not interfere with its proper ventilation.

To maintain good ventilation, do not put records or a table-cloth on the appliance. Place the appliance at least 10 cm away from the walls.

Do not use the appliance on a bed, sofa, rug or similar surface that may block the ventilation openings. This appliance should not be placed in a built-in installation such as a bookcase or rack unless proper ventilation is provided or the manufacturer's instructions have been adhered to.

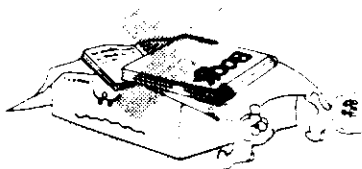

- 5. Water and moisture** – The appliance should not be used near water – for example, near a bathtub, washbowl, kitchen sink, laundry tub, in a wet basement, or near a swimming pool, etc.

- 6. Temperature** – The appliance may not function properly if used at extremely low, or freezing temperatures. The ideal ambient temperature is above +5°C (41°F).
- 7. Heat** – The appliance should be situated away from heat sources such as radiators, heat registers, stoves, or other appliances (including amplifiers) that produce heat.
- 8. Electric shock** – Care should be taken so that objects do not fall and liquid is not spilled into the enclosure through openings. If a metal object, such as a hair pin or a needle, comes into contact with the inside of this appliance, a dangerous electric shock may result. For families with children, never permit children to put anything, especially metal, inside this appliance.

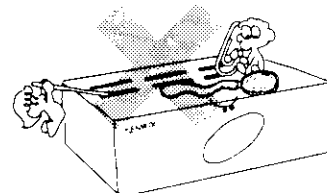

- 9. Enclosure removal** – Never remove the enclosure. If the internal parts are touched accidentally, a serious electric shock might occur.

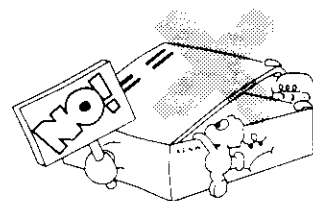

- 10. Magnetic fields** – Keep the appliance away from sources of magnetic fields such as TV sets, speaker systems, radios, motorized toys or magnetized objects.

- 11. Cleaning** – Unplug this appliance from the wall outlet before cleaning. Do not use volatile solvents such as alcohol, paint thinner, gasoline, or benzene, etc. to clean the cabinet. Use a clean dry cloth.

- 12. Accessories** – Do not place this appliance on an unstable cart, stand, tripod, bracket, or table. The appliance may fall, causing serious injury to a child or adult, and serious damage to the appliance. Use only with a cart, stand, tripod, bracket, or table recommended by the manufacturer, or sold with the appliance. Any mounting of the appliance should follow the manufacturer's instructions, and should use a mounting accessory recommended by the manufacturer. An appliance and cart combination should be moved with care. Quick stops, excessive force, and uneven surfaces may cause the appliance and cart combination to overturn.



13. Lightning – For added protection for this appliance during a lightning storm, or when it is left unattended and unused for long periods of time, unplug it from the wall outlet and disconnect the antenna or cable system. This will prevent damage to the appliance due to lightning and power-line surges.

14. Abnormal smell – If an abnormal smell or smoke is detected, immediately turn the power OFF and unplug the appliance from the wall outlet. Contact your dealer or nearest service center.

POWER OFF!

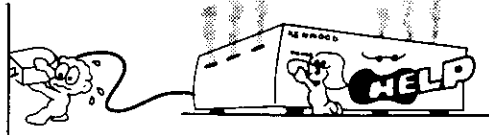

15. Damage requiring service – The appliance should be serviced by qualified service personnel when:

- A. The power-supply cord or the plug has been damaged.
- B. Objects have fallen, or liquid has been spilled into the appliance.
- C. The appliance has been exposed to rain or water.
- D. The appliance does not appear to operate normally by following the instruction manual. Adjust only those controls that are covered by the instruction manual as an improper adjustment of other controls may result in damage and will often require extensive work by a qualified technician to restore the appliance to its normal operation.
- E. The appliance has been dropped, or the enclosure damaged.
- F. The appliance exhibits a marked change in performance.

16. Servicing – The user should not attempt to service the appliance beyond that described in the instruction manual. All other servicing should be referred to qualified service personnel.

17. Outdoor antenna grounding – If an outside antenna is connected to the appliance, be sure the antenna system is grounded so as to provide some protection against voltage surges and built up static charges. Article 810 of the National Electrical Code ANSI/NFPA 70, provides information with respect to proper grounding of the mast and supporting structure, grounding of the lead-in wire to an antenna discharge unit, size of grounding conductors, location of antenna discharge unit, connection to grounding electrodes, and requirements for the grounding electrode. See Figure.

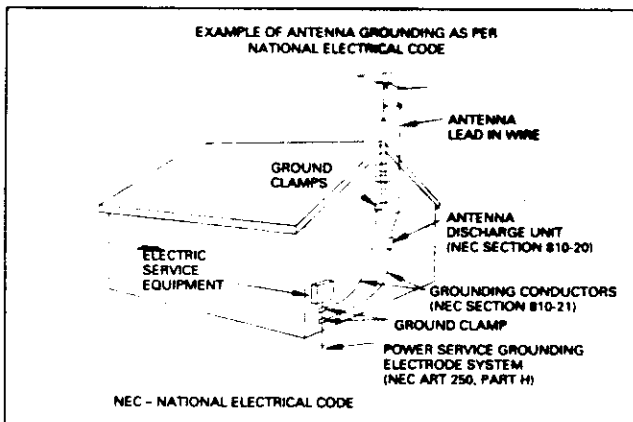

18. Power lines – An outside antenna system should not be located in the vicinity of overhead power lines or other electric light or power circuits, or where it can fall into such power lines or circuits. When installing an outside antenna system, extreme care should be taken to keep from touching such power lines or circuits as contact with them might be fatal.

19. AC outlets – Do not connect other audio equipment with a power consumption larger than that specified to the AC outlet on the rear panel. Never connect other electrical appliances, such as an iron or toaster, to it to prevent fire or electric shock.

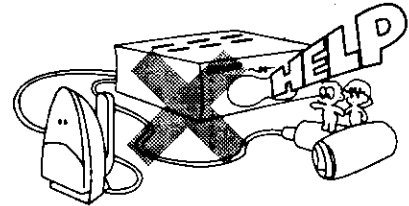

20. Overloading – Do not overload wall outlets, extension cords, or integral convenience receptacles as this can result in a risk of fire or electric shock.

21. Attachment – Do not use attachments not recommended by the appliance manufacturer as they may cause hazards.

22. Replacement parts – When replacement parts are required, be sure the service technician has used replacement parts specified by the manufacturer or have the same characteristics as the original parts. Unauthorized substitutions may result in fire, electric shock, or other hazards.

23. Safety check – Upon completion of any service or repairs to this appliance, ask the service technician to perform safety checks to determine that the appliance is in proper operating condition.

Notes:

- 1. Item 3 is not required except for grounded or polarized equipment.
- 2. Item 17 and 18 are not required except for units provided with antenna terminals.
- 3. Item 17 complies with UL in the U.S.A.

Connections of audio and video components

Make connection as shown below.

When connecting the related system components, refer also to the instruction manuals of the related components.

Do not plug in the power lead until all connections are completed.

Malfunction of microcomputer

If operation is not possible or erroneous display appears even though all connections have been made properly, reset the microcomputer referring to "In case of difficulty".

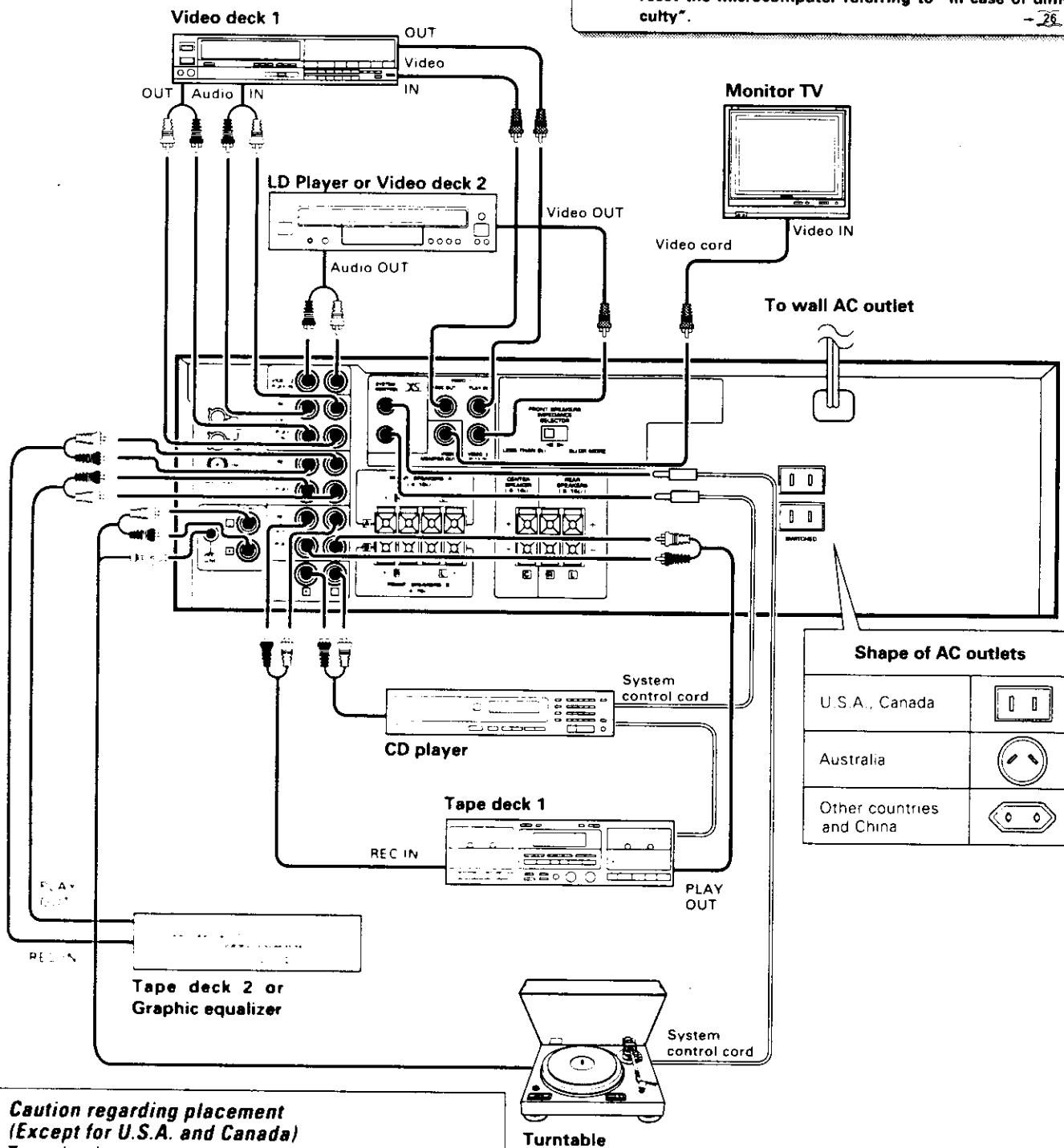

Caution regarding placement (Except for U.S.A. and Canada)

To maintain proper ventilation, be sure to leave a space around the unit (from the largest outer dimensions including projections) equal to, or greater than, shown below.

Left and right panels: 10 cm
Rear panel: 10 cm
Top panel: 50 cm

About the system control connections

Connecting system control cords after connecting a KENWOOD audio component system lets you take advantage of convenient system control operations.

There are two KENWOOD system control modes. Make connections according to the groups of terminal symbols shown below.

[XS8] Mode: lets you combine **[XS]**, **[XR]**, and **[XS8]** terminals

[SL16] Mode: for **[SL16]** terminals only

This unit is only compatible with the [XS8] mode and cannot be connected in the [SL16] mode.

EXAMPLE: [XS8] mode connections

The underlined portion represents the setting of the system control mode.

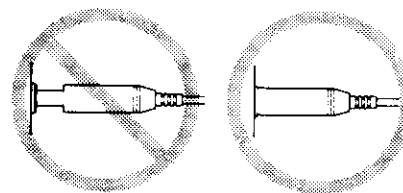
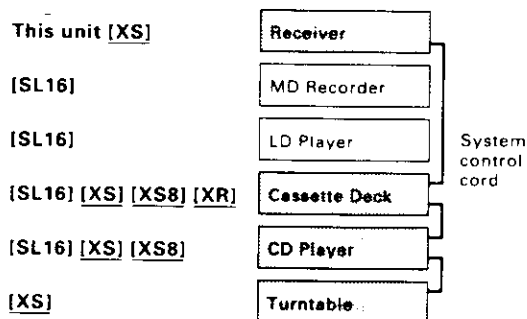

- Certain CD players and cassette deck may or may not be compatible with the [XS8] mode. Do not make system connections to incompatible components.



1. [SL16] equipment cannot be combined with [XR], [XS], and [XS8] equipment for system operations. If your equipment consists of this kind of combination, please do not connect any system control cords. Even without system control cords, normal operations can be carried out without affecting performance.
2. Do not connect system control cords to any components other than those specified by KENWOOD. It may cause a malfunction and damage your equipment.
3. Be sure the system control plugs are inserted all the way in to the system control terminals.

ABOUT THE SYSTEM CONTROL OPERATIONS

Remote Control

Lets you operate source components with the system remote supplied with this unit.

Automatic Operation (Except [XR] equipment)

When this unit is connected to KENWOOD system components such as a cassette deck and CD player through system control cords and the input source is selected with the INPUT SELECTOR, the selected component starts to play automatically. Inversely, playing a component automatically selects that source as the input to this unit. The automatic operation also occurs when the provided remote control is used. (Except for TAPE 2 and video components)

Synchronized Recording (Except [XR] equipment)

Lets you synchronize recording with the start of playback when recording from CD, MD, LD, or analog discs.

Do not connect system control cord to the cassette deck connected to the TAPE 2 (MONI.) jacks.



1. Connect all cords firmly. If connections are loose, there could be loss of sound or noise produced.
2. When plugging and unplugging connection cords, be sure to first remove the power cord from the AC outlet. Plugging / unplugging connection cords without removal of the power cord can cause malfunctions or damage to the unit.
3. Do not connect up a power source which is larger than that indicated on the socket at the rear of the unit.
4. If the system control cords or audio cords are not connected properly, the remote control or automatic operation between system components will not work properly.

Connection of speakers

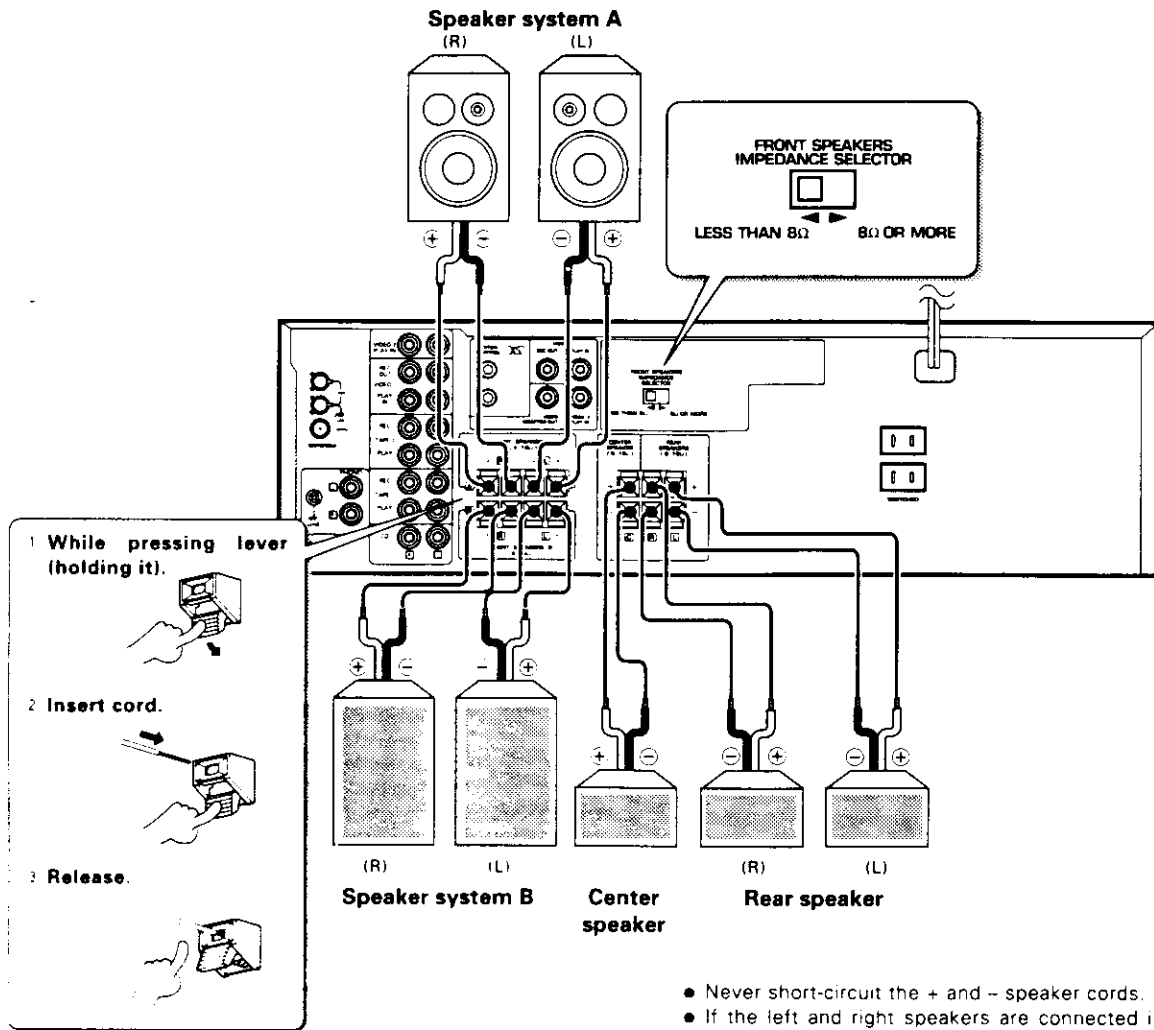

- Never short-circuit the + and - speaker cords.
- If the left and right speakers are connected inversely or if the speaker cords are connected with reversed polarity, the sound becomes unnatural with ambiguous acoustic image positioning. Be sure to connect the speakers and speaker cords correctly.
- Proper sound will not be produced unless two rear speakers are connected.

Setting the speaker IMPEDANCE SELECTOR

Speaker impedance	Selector position
4 Ω, 6 Ω	
8 Ω, 16 Ω	

CAUTION: TO PREVENT FIRE OR DAMAGE REQUIRING SERVICE, SET THE IMPEDANCE SELECTOR SWITCH AS DESCRIBED BELOW.

According to the impedance of the speakers used, set the speaker **IMPEDANCE SELECTOR** on the rear panel as shown in the table.

- During speaker system connection and operation of the speaker **IMPEDANCE SELECTOR**, set the power key to OFF.

Connection of antenna

Connection method to each antenna terminal

- 1 Loosen the screw.
- 2 Wrap the cord
- 3 Tighten the screw

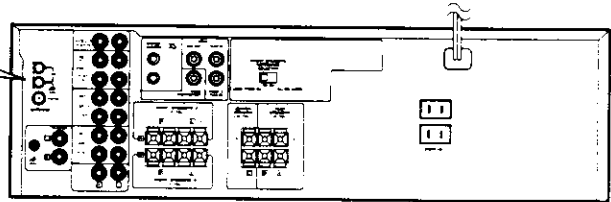
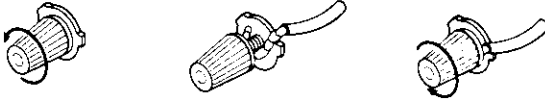

AM loop antenna connection

The supplied antenna is for indoor use. Place it as far as possible from the main system, TV set, speaker cords and power cord, and set it to a direction which provides the best reception.

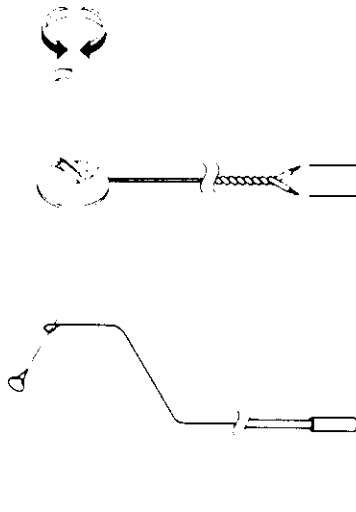

AM outdoor antenna connection

If the reception is poor when the AM loop antenna is used, distribute a vinyl-coated wire of more than 6 meters outdoors, without disconnecting the loop antenna.

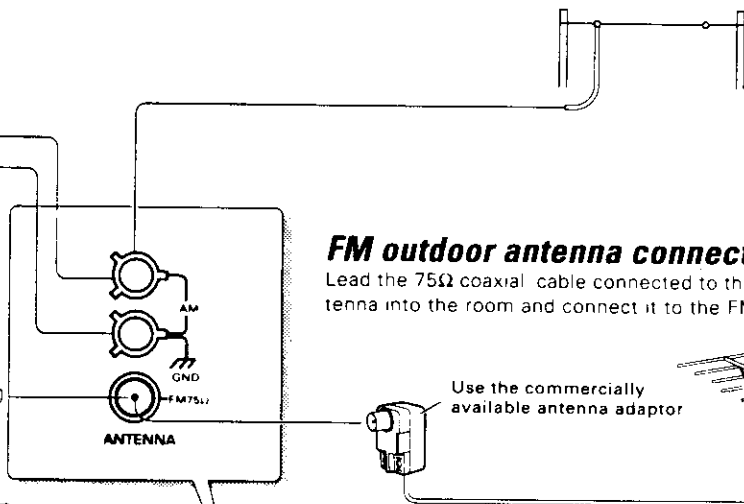

FM outdoor antenna connection

Lead the 75Ω coaxial cable connected to the FM outdoor antenna into the room and connect it to the FM 75Ω terminal.

FM indoor antenna connection

The accessory antenna is for temporary indoor use only. For stable signal reception, we recommend using an outdoor antenna. Remove the indoor antenna if you connect one outdoors.

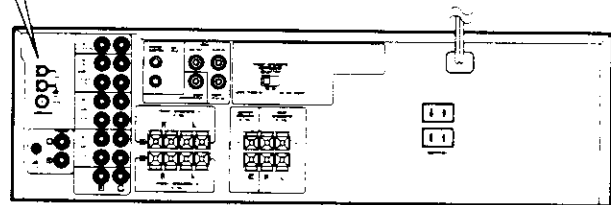

FM DE-EMPHASIS / CHANNEL SPACE switch (Except for U.S.A., Canada and Australia)

The FM DE-EMPHASIS / CHANNEL SPACE switch on the rear panel is set to the correct setting that prevails in the area to which the unit is shipped. However, if the FM DE-EMPHASIS / CHANNEL SPACE setting is not matched to the area where the unit is to be used, for instance, when you moved from area 1 to area 2 or vice versa, desired reception of AM / FM broadcasts is not expected. In this case, change the FM DE-EMPHASIS / CHANNEL SPACE setting in accordance with the area corresponding to the table. The FM DE-EMPHASIS is switched over at the same time.

- When changing the setting of the FM DE-EMPHASIS / CHANNEL SPACE switch, first disconnect the power cord, then reset the channel space switch, connect the power cord again, and turn the power on.

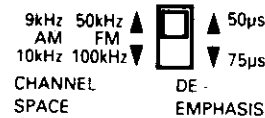
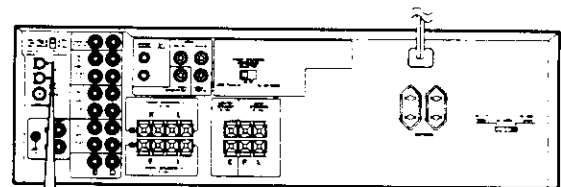

	Area	CHANNEL SPACE freq.	FM DE-EMPHASIS
1	U.S.A., Canada and South American countries	FM 100kHz AM 10kHz	75 µs
2	Other countries	FM 50kHz AM 9kHz	50 µs

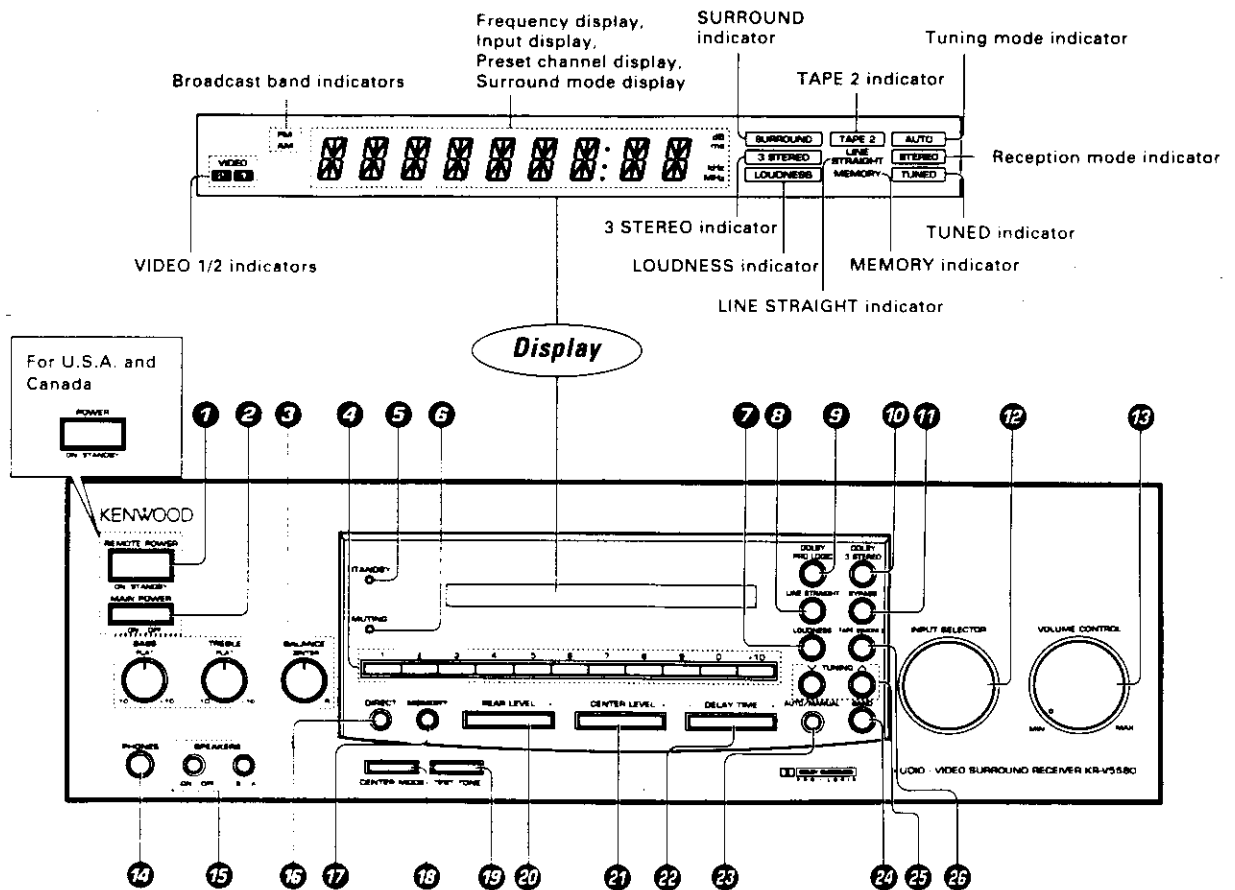

❶ REMOTE POWER key

Press to switch over the STANDBY-ON modes when the MAIN POWER is ON

❷ MAIN POWER switch

Press to switch the main power ON, OFF

❸ Sound adjustment knobs

❹ Numeric keys

Used for storing and recalling stations

❺ STANDBY indicator

❻ MUTING indicator

❼ LOUDNESS key

Press to enhance low frequencies

❽ LINE STRAIGHT key

Press to reproduce the source with a higher sound quality

❾ DOLBY PRO LOGIC key

❿ DOLBY 3 STEREO key

⓫ BYPASS key

Press to cancel the surround modes

⓬ INPUT SELECTOR knob

Turn to select the input sources

⓭ VOLUME CONTROL knob

⓮ PHONES jack

Used for headphone listening

⓯ SPEAKERS A/B keys

Press to select the A and/or B speaker systems

⓰ DIRECT key

Press for direct station tuning based on numerical input

⓱ MEMORY key

Press to preset a station in memory

⓲ CENTER MODE key

Press to select the center mode for the DOLBY PRO LOGIC surround and DOLBY 3 STEREO modes

⓳ TEST TONE key

⓴ REAR LEVEL key

Adjusts volume of rear speakers

⓵ CENTER LEVEL key

Adjusts the volume of the center speaker

⓶ DELAY TIME key

Adjusts the delay time

⓷ AUTO/MANUAL key

Press to select the auto tuning mode

⓸ BAND key

Press to switch the broadcast band

⓹ TUNING keys

Press to tune broadcast stations

⓺ TAPE 2 (MONI.) key

Press to monitor the sound being recorded

About the STANDBY indicator

This unit has a **STANDBY** indicator. When the **STANDBY** indicator is lit, the unit consumes a small amount of power to preserve the memory. This is called **STANDBY** mode. This mode also lets you turn the power ON/OFF using the remote control

Remote control unit

The remote control unit provided with the receiver can also control KENWOOD cassette decks, and CD player connected to the receiver through system control cords. For details of the controllable functions, refer to the instruction manuals of these components.

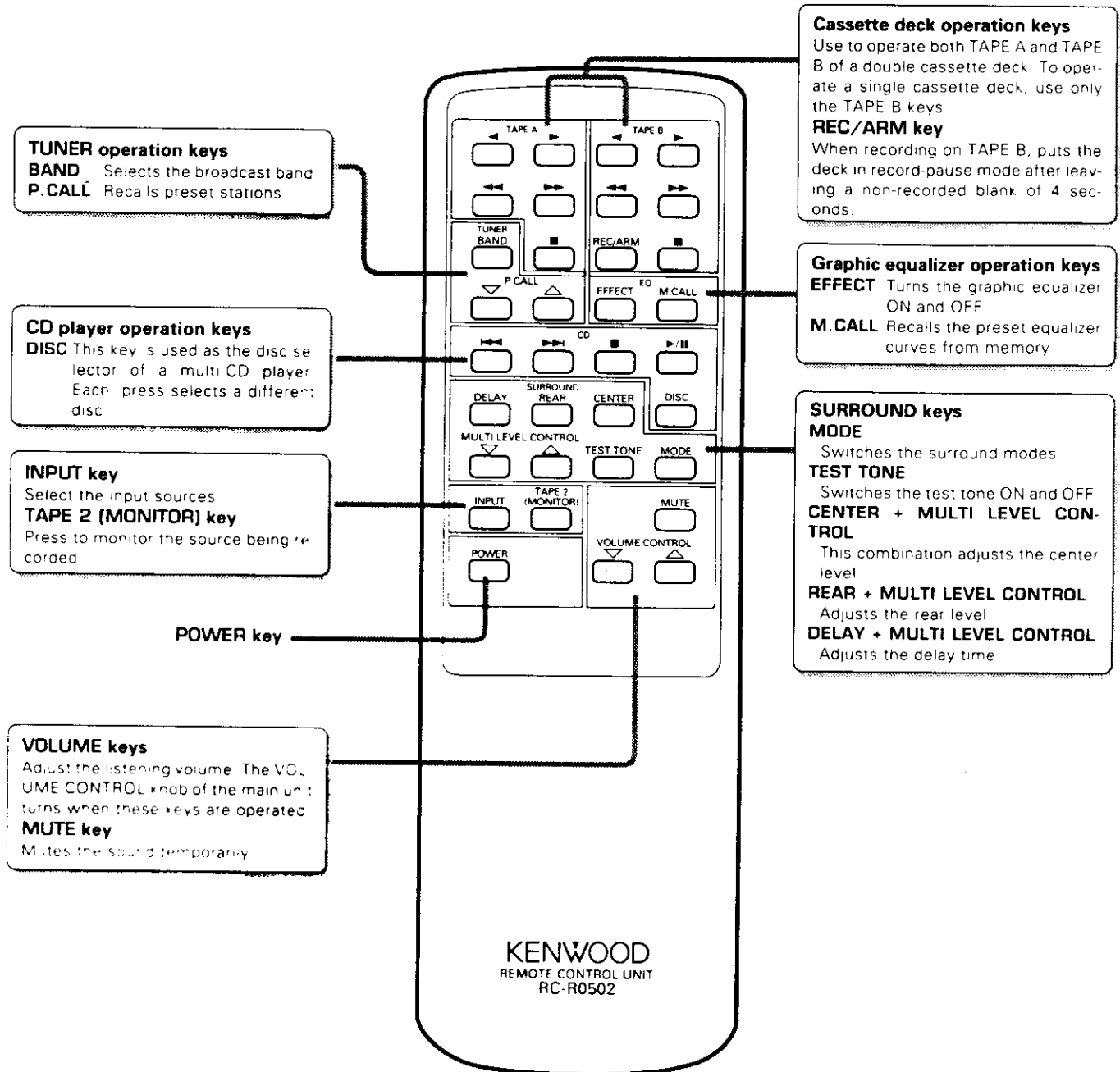

Model: RC-R0502
 Infrared ray system

Operation of remote control unit

KR-V558D (En)

2 Loading batteries

1 Remove the cover.

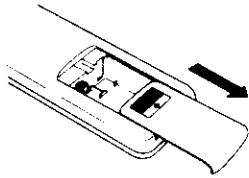

2 Insert batteries.

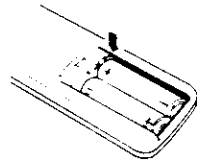

3 Close the cover.

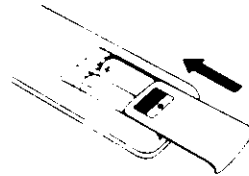

- Insert two AA-size (R6 / SUM-3) batteries as indicated by the polarity marking.

Operation procedure

When the **STANDBY** indicator is lit, the power turns **ON** when you press the **POWER** key on the remote. When the power comes **ON**, press the key you want to operate.

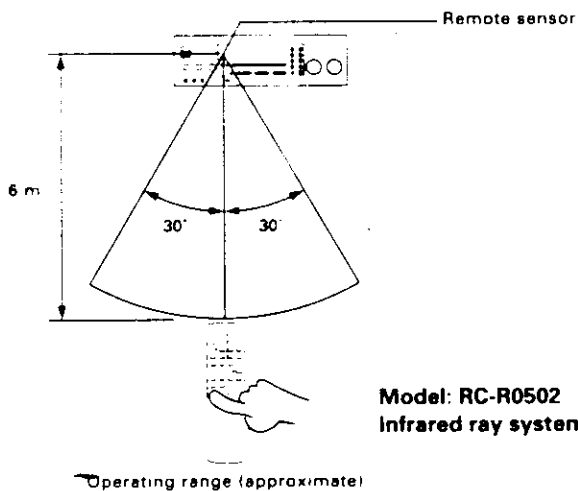

- Components connected via the system control cords, such as the CD player, can also be remote-controlled. In this case, please read the instruction manual supplied with your components.
- When two operation keys on the remote control unit are pressed successively, press each key securely reserving an interval of more than 1 second for each press.



- 1 The supplied batteries are intended for use in operation checks. Therefore, their lives may be shorter than ordinary batteries.
- 2 When the remote-controllable distance gets shorter than before, replace both batteries with new ones.
- 3 Malfunction may occur if direct sunlight or the light of a high-frequency lighting fluorescent lamp enters the remote control light sensor. In such a case, change the system installation position to prevent the malfunction.

Playing music

KR-V5580 (En)

Preparation (Except for U.S.A. and Canada)

- Press the **MAIN POWER** key to ON.

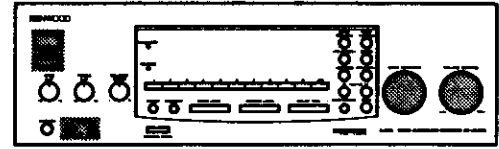
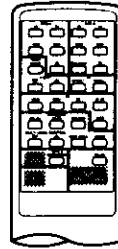
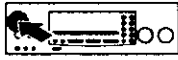

 : Keys or controls to be used in this operation

1 Turn the power ON.

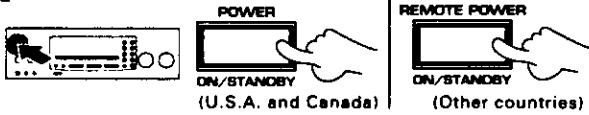

2 Select the SPEAKERS key setting.

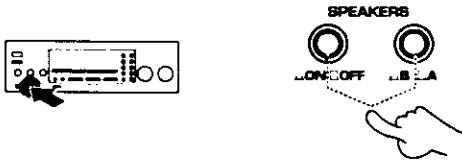

3 Select the input source.

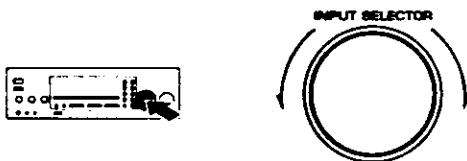

4 Play the selected source.

5 Adjust the volume.

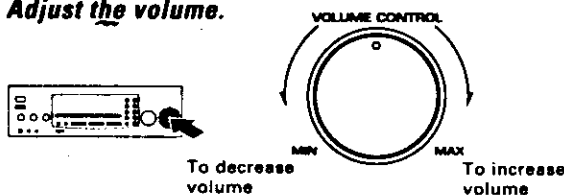

□ OFF

Sound is not output from the speakers. Use this setting for listening through headphones, etc.

▢ ON, □ A

Sound is output from the speakers connected to the SPEAKERS A terminals on the rear panel.

▢ ON, ▢ B

Sound is output from the speakers connected to the SPEAKERS B terminals on the rear panel.

- If the cassette deck(s), CD player and/or turntable is connected through system control cords, the component of the selected input source starts to play automatically.

The input sources are switched in the following order:

- ① TUNER (frequency display)
- ② TAPE 1
- ③ VIDEO 1
- ④ VIDEO 2
- ⑤ []
- ⑥ PHONO

The selected source is displayed.

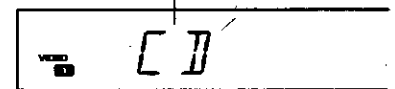

- The sound of input source cannot be listened to while **TAPE 2 (MONI.)** is ON. (Except when the graphic equalizer is connected )
- When the volume is adjusted from the remote control unit, the **VOLUME CONTROL** knob rotates.

Sound adjustment functions

KR-V5580 (En)

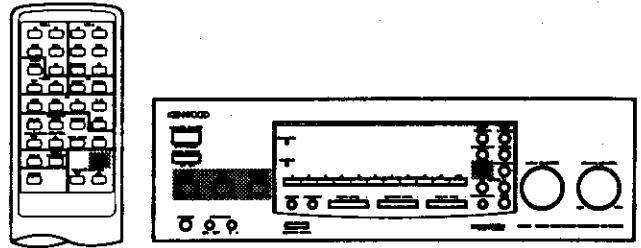

■ : Keys or controls to be used in this operation

Adjusting the tone

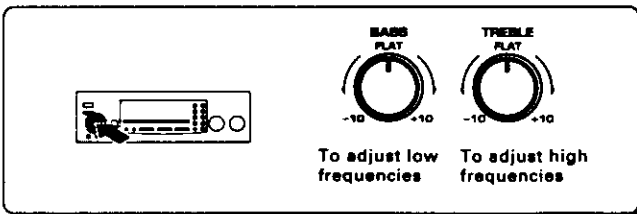

Adjusting the left/right sound balance

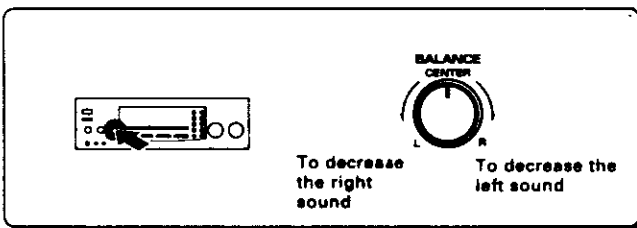

Using the LOUDNESS key

When listening at a low volume, the loudness function allows to compensate the low frequencies which human ears have difficulty in hearing at a low volume.

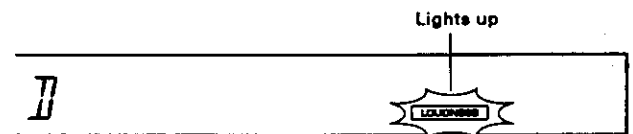
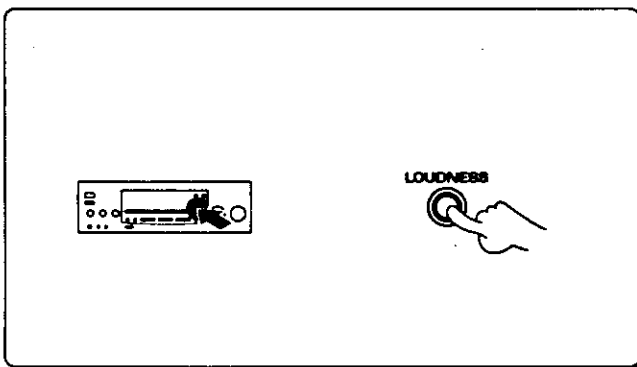

To cancel
Press the LOUDNESS key again.

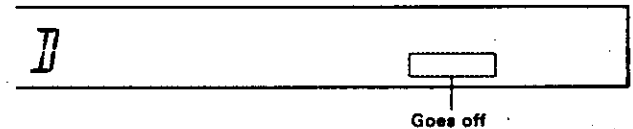

To mute sound temporarily

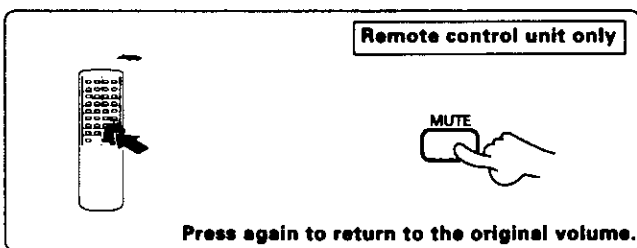

● The indicator on the main unit blinks.

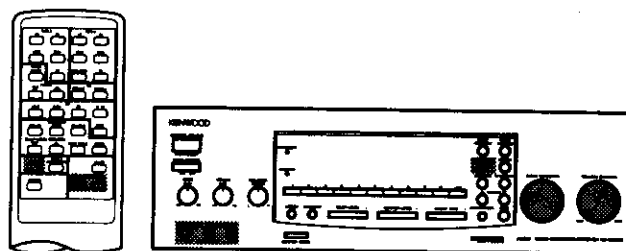

: Keys or controls to be used in this operation

To listen through headphones

① Set both of the **SPEAKERS** keys to OFF.

② Plug headphones.

③ Adjust the volume.

To decrease volume To increase volume

Line-straight playback

This feature allows you to enjoy music sources such as CD with an even higher sound quality.

① Select the source to be played.

② Press the **LINE STRAIGHT** key.

③ Play the source.

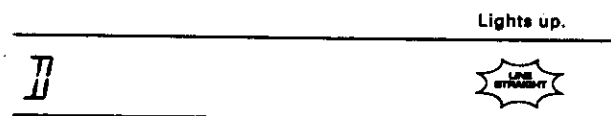

- The tone control functions are defeated during line-straight play.
- The line-straight play is cancelled when a key associated with surround play is pressed.

To cancel
Press the **LINE STRAIGHT** key again.

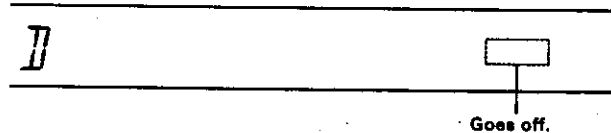

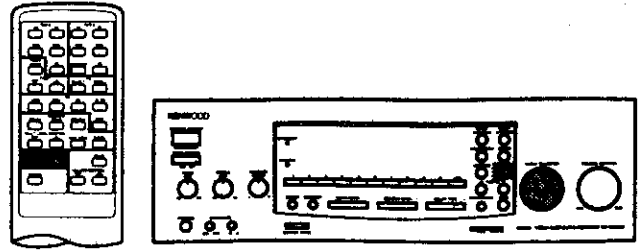

■ : Keys or controls to be used in this operation

To record a music source

- ① Select the source to be recorded.

INPUT SELECTOR

Select input source other than TAPE 1.

- ② Put the cassette deck in record-pause mode.
- ③ Play the source and start recording.

Copying tape (Tape dubbing TAPE 2 → TAPE 1)

- ① Press the TAPE 2 (MONI.) key.

TAPE 2(MONI.)

- ② Select a source other than TAPE 1.

INPUT SELECTOR

- ③ Play cassette deck 2 and start recording on cassette deck 1.



● For copying a tape using a double cassette deck, read the instruction manual of the double cassette deck.

Copying tape (Tape dubbing TAPE 1 → TAPE 2)

- 1 Select TAPE 1 with the INPUT SELECTOR knob of the main unit.
- 2 Play the cassette deck connected to the TAPE 1 jacks and start recording of the cassette deck connected to the TAPE 2 jacks.

Regarding TAPE 2(MONITOR)

A cassette deck or graphic equalizer can be connected to this unit's TAPE 2(MONI.) terminals. If you connect a graphic equalizer, turn the TAPE 2(MONI.) key ON. If you connect a 3-head cassette deck, you can monitor the source sound, or the sound being recorded, while recording. Pressing the TAPE 2(MONI.) key lets you compare the recorded sound and the source sound. Refer to the operating manual for the component you connected for further details.

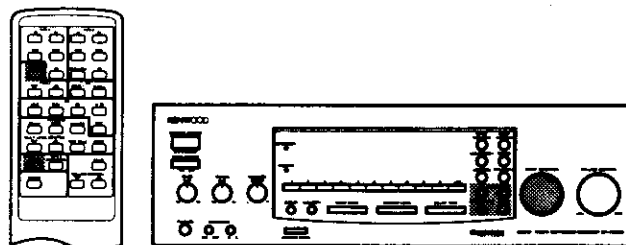

 : Keys or controls to be used in this operation

Receiving broadcast stations

1 Select the TUNER input.

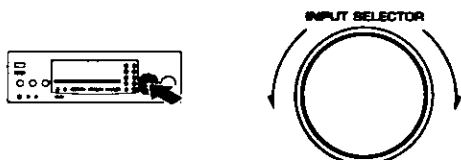

The input sources are switched in the following order:

- ① TUNER (frequency display)
- ② TAPE 1
- ③ VIDEO 1
- ④ VIDEO 2
- ⑤ [C]
- ⑥ PHONO

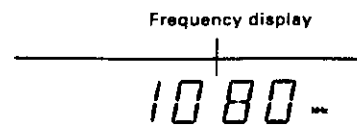

- The last frequency tuned before is displayed.

2 Select the broadcast band.



Each press switches the band as follows:

- ① FM
- ② AM

"AM" or "FM" indicator

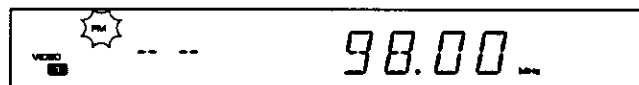

3 Select the tuning method.



Each press switches the turning method as follows:

- ① AUTO lit (auto tuning)
- ② AUTO not lit (manual turning)

Lights up.

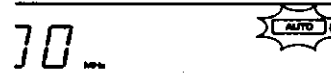

- Usually, set the switch to **AUTO** (auto tuning).

Select manual tuning when noise interferes due to weak radio wave.
(The stereo broadcasting is received in monaural during manual tuning.)

4 Select a station.

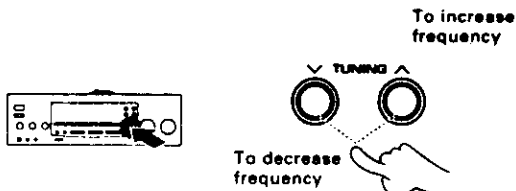

Frequency display

"TUNED" lights up when a station is turned.

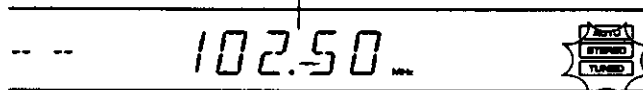

For Auto Tuning: Press \vee or \wedge once and the tuner automatically tunes to a receivable station.

For Manual Tuning: Press repeatedly until the frequency you desire is tuned. You can also tune by holding the button down.

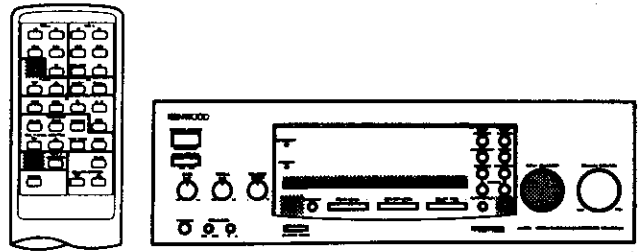

■ : Keys or controls to be used in this operation

Receiving radio stations by specifying its frequency

1 Select the TUNER input.

The input sources are switched in the following order:

- ① TUNER (frequency display)
- ② TAPE 1
- ③ VIDEO 1
- ④ VIDEO 2
- ⑤ [E]
- ⑥ PHONO

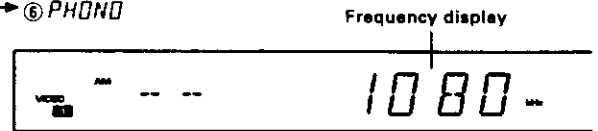

2 Select the broadcast band.

Each press switches the band as follows:

- ① FM
- ② AM

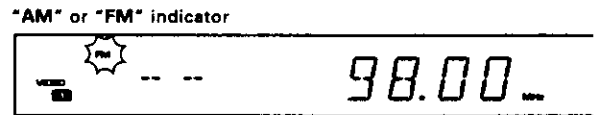

3 Specify the frequency.

① Press the DIRECT key.

② Enter the frequency of the desired station.

Press the numeric keys according to the frequency to be tuned as shown below.

Desired station	Order of pressing numeric keys	
FM 90 MHz	9 . 0 . 0	(100 kHz space)
	9 . 0 . 0 . 0	(50 kHz space)
FM 102.5 MHz	1 . 0 . 2 . 5	(100 kHz space)
	1 . 0 . 2 . 5 . 0	(50 kHz space)
AM (MW) 810 MHz	8 . 1	(10 kHz space)
	8 . 1 . 0	(9 kHz space)
AM (MW) 1260 kHz	1 . 2 . 6	(10 kHz space)
	1 . 2 . 6 . 0	(9 kHz space)

*FM DE-EMPHASIS/CHANNEL SPACE switch - []

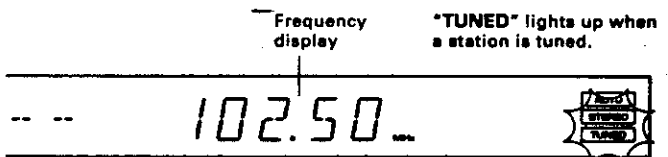

● If you made a mistake, repeat step 3 again.

Preparation

- Tune the station to be stored in memory. 

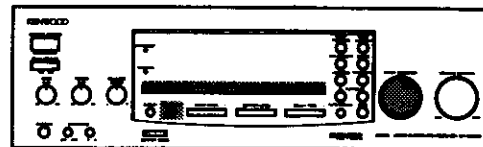
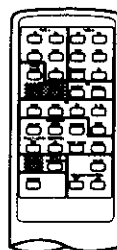

 : Keys or controls to be used in this operation

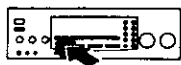

Storing radio stations in memory (Station preset)

① Press the MEMORY key during receiving a station.





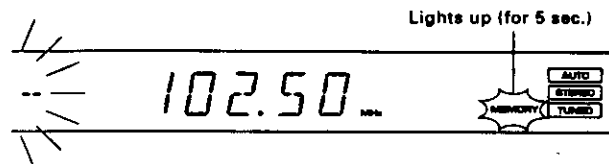

Proceed to step 2 within 5 sec.
(If more than 5 sec. have elapsed, press the MEMORY key again.)

② Select one of the preset numbers from 1 to 20.

Press the numeric keys in the following order.

- To store in "15"  , 
- To store in "20"  ,  , 



- Repeat steps ① and ② for each of the stations to be stored in memory.
- If a station is stored in a preset number which already stores a station memory under it, the previous memory is replaced by the new memory content.

Receiving a preset station

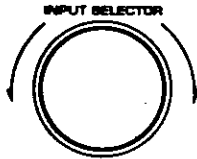

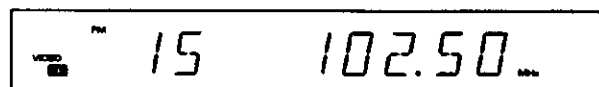

① Select the TUNER input with the INPUT SELECTOR.

② Press the preset number of the desired station.







Press the numeric keys in the following order.

- To recall "15"  , 
- To recall "20"  ,  , 

Receiving all preset stations in order

Press the P.CALL key.

- Every time the key is pressed, the next station in the order of the preset number is received.

When you press Δ key..... 

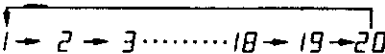
When you press ∇ key..... 

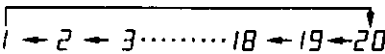
If the key is held pressed Preset stations will be received successively for about half a second each.

Operation of video components

KR-V5580 (En)

For the connections and operations, also read carefully the instruction manuals of the video components. 

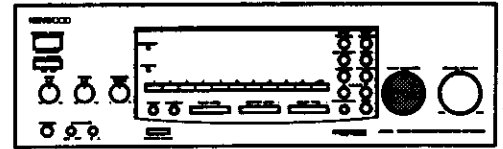
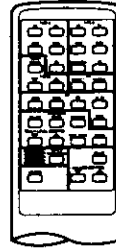

 : Keys or controls to be used in this operation

Playback of videotape

1 Turn the power of the monitor TV ON.

2 Select the VIDEO 1 input.

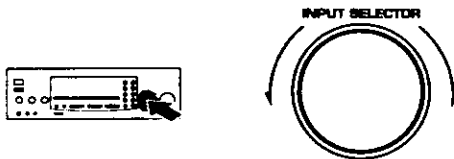

3 Play the video deck.

The input sources are switched in the following order:

- ① TUNER (frequency display)
- ② TAPE 1
- ③ VIDEO 1
- ④ VIDEO 2
- ⑤ [C]
- ⑥ PHONO

"VIDEO 1" should be displayed.

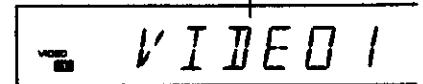

- Select the input to which a video deck is connected.

Recording of video source

1 Connect the video source component to be played.

2 Select the VIDEO 2 input.



3 Play the source component.

4 Start recording on the recording video deck.

- Connect the component to be played to the VIDEO 2 jacks.
- The connectable components include a video deck (playback only), video camera (playback only), LD player or DBS tuner.

The input sources are switched in the following order:

- ① TUNER (frequency display)
- ② TAPE 1
- ③ VIDEO 1
- ④ VIDEO 2
- ⑤ [C]
- ⑥ PHONO

"VIDEO 2" should be displayed.



- Start recording with the video deck which is connected to the VIDEO 1 jacks.

The surround modes allow to enjoy the feeling of presence in music. Select the mode according to the source or components played. For the connections of the rear and/or center speakers, refer to "Connection of speakers". 

DOLBY PRO LOGIC surround mode

Video and LD software programs carrying the  mark contain recording of the same Dolby Surround data as those used in movie theaters. The DOLBY PRO LOGIC surround mode uses the Dolby Surround data and brings into home a similar sound field with full of presence to movie theater. To use this mode, connect the rear (and center) speakers.

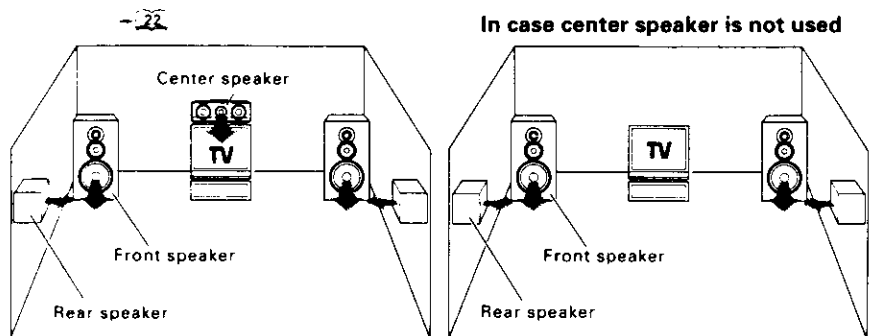

DOLBY 3 STEREO mode

If the left and right speakers are installed apart from each other, the center acoustic image (words, etc.) may vary depending on the listener's position. The DOLBY 3 STEREO mode provides an improved positioning of the center acoustic image regardless of the listening position. To use this mode, connect the center speaker.

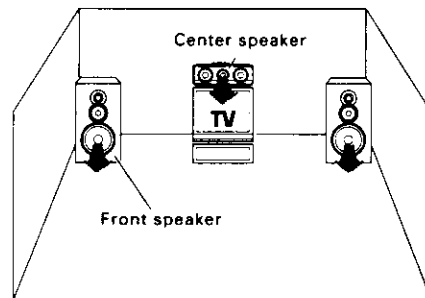

Recommended speaker installation



It is recommended that the rear speakers are installed straight to the left and right of the listening position or slightly behind, at a height of about 1 meter higher than the listener's ears. Each rear speaker should be installed so that the longer sides are horizontal.

When video (LD) software carrying  mark is played, this mode provides the Dolby Surround effect, similar to movie theaters.

Manufactured under license from Dolby Laboratories Licensing Corporation.
DOLBY, the double-D symbol and "PRO LOGIC" are trademarks of Dolby Laboratories Licensing Corporation.

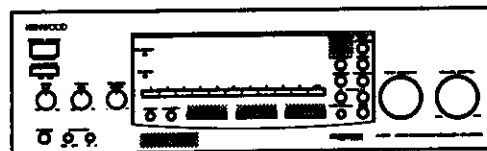
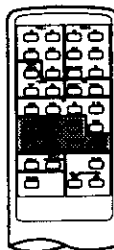

 : Keys or controls to be used in this operation

DOLBY PRO LOGIC surround arrangement

1 Activate the DOLBY PRO LOGIC mode.

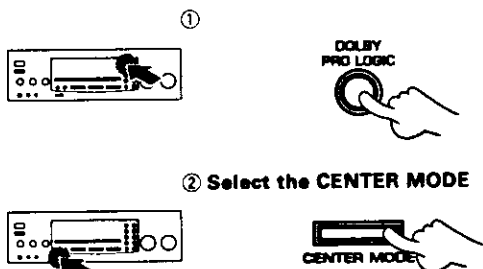

2 Select the CENTER MODE



2 Adjust the volume balance.

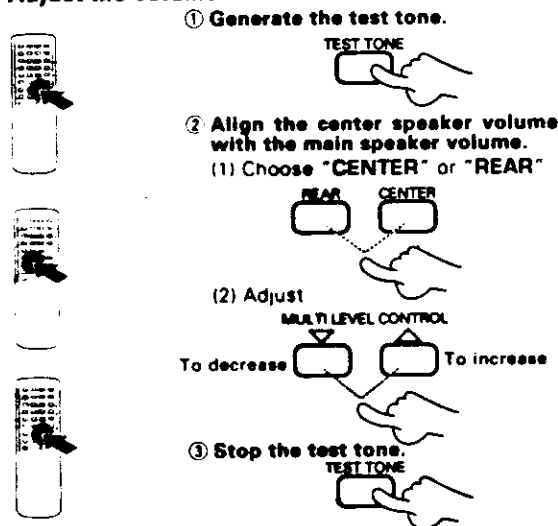

3 Adjust the delay time.

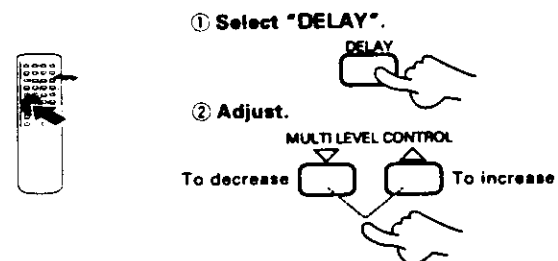

Lights up.

PRO LOGIC 

Each press of the **CENTER MODE** key switches the center modes as follows:

- ① **NORMAL** : When the center speaker is a compact-sized speaker.
 - ② **WIDE BAND** : When the center speaker is a medium- or large-sized speaker.
 - ③ **PHANTOM** : When the center speaker is not used.
- If you cannot tell whether your center speaker is compact or medium-sized, try two modes and select according to your liking.
 - The selected center mode is automatically stored in memory and held unless it is changed later.

- The test tone which is heard like noise moves between speakers at an interval of 1.5 sec.

In NORMAL and WIDE BAND modes:

- Left (L)
- Center (C)
- Right (R)
- Surround (Rear) (S)

In PHANTOM mode:

- Left (L)
- Right (R)
- Surround (Rear) (S)

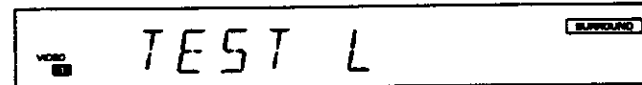

- Be sure to adjust from your listening position.
- The volume is adjusted in 1dB steps each time you press the **MULTI LEVEL CONTROL** keys.
- The volume levels can be adjusted in the range from -10 dB to +10 dB.

- The delay time can be adjusted in the range from 15 ms to 30 ms, in 5 ms steps.
- Once the delay time has been preset, it is held until it is re-set later.



How to calculate the proper delay time

This mode improves the positioning of the acoustic image of words, etc., by applying directivity enhancer processing and using an additional center speaker when a video software program recorded with ordinary 2-channel stereo is played.

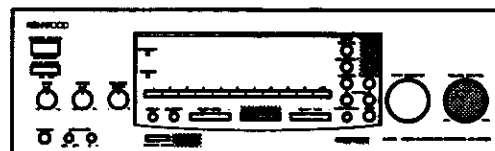
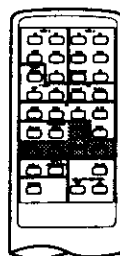

■ : Keys or controls to be used in this operation

DOLBY 3 STEREO adjustment and playback

1 Activate the DOLBY 3 STEREO mode.

① DOLBY 3 STEREO

② Select the CENTER MODE.

2 Adjust the volume balance.

① Generate the test tone.

TEST TONE

② Align the center speaker volume with the main speaker volume.

(1) Select "CENTER".

CENTER

(2) Adjust

MULTI LEVEL CONTROL

decreases level increases level

③ Stop the test tone.

TEST TONE

3 Play a video software program.

4 Adjust the volume.

VOLUME CONTROL

To decrease To increase

Lights up.



Each press of the **CENTER MODE** key switches the center modes as follows:

- ① **NORMAL** :When the center speaker is a compact-sized speaker.
- ② **WIDE BASS** :When the center speaker is a medium- or large-sized speaker.

- If you cannot tell whether your center speaker is compact or medium-sized, try two modes and select according to your liking.
- The selected center mode is automatically stored in memory and held unless it is changed later.

- The test tone which is heard like noise moves between speakers at an interval of 1.5 sec.

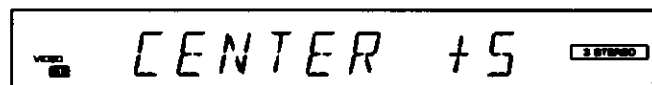
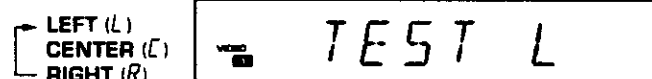

- Be sure to adjust from your listening position.
- The center level is adjusted in 1dB steps each time you press the **MULTI LEVEL CONTROL** keys.
- The center level can be adjusted in the range from -10 dB to +10 dB.
- The center level is stored in memory as the common settings with the "DOLBY PRO LOGIC" mode.

To cancel DOLBY 3 STEREO play

MODE

Select OFF.

Remote control unit

BYPASS

Main unit

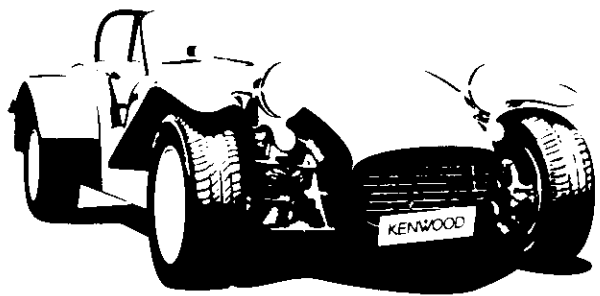

26

Operation to reset

The microcomputer may fall into malfunction (impossibility to operate, erroneous display, etc.) when the power cord is unplugged while power is ON or due to an external factor. In this case, execute the following procedure to reset the microcomputer and return it to normal condition.

- For U.S.A. and Canada:
Unplug the power cord from the power socket and, while holding the POWER key depressed, plug the power cord into the socket again.
- For other countries:
While holding the REMOTE POWER key depressed, press the MAIN POWER key to ON.

● Please note that resetting the microcomputer clears the contents stored in and returns to the condition when it left the factory.

Remote control unit

Symptom	Cause	Remedy
Remote control operation is not possible.	<ul style="list-style-type: none"> ● Batteries are exhausted. ● The remote control unit is too far away from the main system, controlling angle is too large, or there is an obstacle in between. ● The audio cords and system control cords are not connected properly. ● The source component to be operated does not contain the tape(s) or CD. ● An attempt is made to play a tape which is being recorded in the cassette deck 	<ul style="list-style-type: none"> ● Replace with new batteries ● Operate the remote control unit within the controllable range - 12 ● Connect properly referring to "System connection" - 6 ● Place the tape(s) or CD in the source component to be played. ● Wait until the recording is completed.

Amplifier

Symptom	Cause	Remedy
Sound is not output.	<ul style="list-style-type: none"> ● The speaker cords are disconnected. ● The VOLUME is set to the minimum position ● MUTE is ON ● The SPEAKERS keys are set to OFF ● The TAPE 2 (MONI.) key is set to ON. 	<ul style="list-style-type: none"> ● Connect them properly referring to "System connection" - 8 ● Adjust the volume to a proper level ● Press the MUTE key to OFF - 14 ● Set the SPEAKERS keys to ON. - 13 ● Set the TAPE 2 (MONI.) key to OFF.
The STANDBY indicator blinks and sound is not output.	<ul style="list-style-type: none"> ● Speaker cords are short-circuited 	<ul style="list-style-type: none"> ● Turn the power off, eliminate the short-circuiting, then turn on the power again - 8
Sound is not output from one of the speakers	<ul style="list-style-type: none"> ● The speaker cord is disconnected ● The BALANCE control is set to an extreme position 	<ul style="list-style-type: none"> ● Connect it properly referring to "System connection" - 8 ● Adjust the Left/Right balance - 14
Sound is not output from the Surround rear speaker and/or center speaker, or their sound is very small	<ul style="list-style-type: none"> ● The rear-speaker cords and/or center speaker cord are disconnected ● The Surround play mode has not been engaged ● The REAR VOL. and/or CENTER VOL. controls are set to the minimum level 	<ul style="list-style-type: none"> ● Connect them properly referring to "System connection" - 8 ● Set the presence mode - 21 ● Adjust the REAR VOL. and CENTER VOL. controls
A hum noise is generated when the PHONO input is selected	<ul style="list-style-type: none"> ● The audio cord from the turntable is not inserted securely into the PHONO jacks ● The turntable is not grounded 	<ul style="list-style-type: none"> ● Insert the audio cord plugs securely into the PHONO jacks - 6 ● Connect the grounding wire to the GND terminal on the rear panel

Tuner

Symptom	Cause	Remedy
Radio stations cannot be received	<ul style="list-style-type: none"> ● An antenna is connected ● The broadcast band is not set properly. ● The frequency of the desired station is not tuned 	<ul style="list-style-type: none"> ● Connect an antenna - 9 ● Set the broadcast band properly. ● Tune the frequency of the desired station - 17
Interference.	<ul style="list-style-type: none"> ● Noise due to ignition noise of an automobile ● Noise due to an influence from an electric appliance ● Noise due to a nearby TV set 	<ul style="list-style-type: none"> ● Install the outdoor antenna apart from the road ● Turn off the power of the appliance ● Install the system more apart from the TV set
A station which was preset cannot be received by pressing the corresponding numeric key.	<ul style="list-style-type: none"> ● The preset station belongs to a frequency that cannot be received ● The preset memory was cleared because the power cord had been unplugged for a long period of time 	<ul style="list-style-type: none"> ● Preset a station with a receivable frequency ● Preset the station again. - 19



Do not use contact cleaners because it could cause a malfunction. Be specially careful against contact cleaners containing oil, for they may deform the plastic components.

Audio section

Rated power output at the STEREO operation

80 watts per channel minimum RMS, both channels driven at 8 Ω , from 40 Hz to 20,000 Hz with no more than 0.06 % total harmonic distortions. (FTC)

Power output at the Surround operation Front

50 watts per channel minimum RMS, both channels driven at 8 Ω , 1 kHz with no more than 0.7 % total harmonic distortions. (FTC)

Center

50 watts minimum RMS at 8 Ω , 1 kHz with no more than 0.7 % total harmonic distortions. (FTC)

Rear

15 watts per channel minimum RMS, both channels driven at 8 Ω , 1 kHz with no more than 0.7 % total harmonic distortions. (FTC)

Total harmonic distortion (1 kHz, 8 Ω) 0.03 % at 50 W
Signal to noise ratio (IHF A)

PHONO (MM) 74 dB

CD 100 dB

Input sensitivity / impedance

PHONO (MM) 2.5 mV / 47 k Ω

CD, TAPE, VIDEO 200 mV / 47 k Ω

Tone controls

BASS \pm 10 dB (at 100 Hz)

TREBLE \pm 10 dB (at 10 kHz)

Loudness control at - 30 dB VOLUME level

..... + 8 dB (100 Hz)

Video section

VIDEO inputs / outputs (Composite) 1 Vp-p / 75 Ω

FM Tuner section

Tuning frequency range 87.5 MHz~108 MHz

Usable sensitivity (IHF) 13.2 dBf (1.2 μ V at 75 Ω)

50 dB quieting sensitivity

STEREO 41.2 dBf (32 μ V at 75 Ω)

Total harmonic distortion at 1 kHz

MONO 0.6 %

STEREO 0.7 %

Signal to noise ratio at 65 dBf (IHF)

MONO 75 dB

STEREO 68 dB

Selectivity (IHF \pm 400 kHz) 50 dB

Stereo separation (IHF at 1 kHz) 40 dB

AM Tuner section

Tuning frequency range 530 kHz ~ 1,700 kHz

Usable sensitivity 12 μ V / (500 μ V / m)

Total harmonic distortion 0.7 %

Signal to noise ratio 48 dB

Selectivity 30 dB

General

Power consumption 2.8 A

AC outlet

SWITCHED 2: (total 150 W, 1.2 A max.)

Dimensions W: 440 mm (17-5/16")

H: 143 mm (5-5/8")

D: 380 mm (14-15/16")

Weight (net) 8.9 kg (19.6 lb)



KENWOOD follows a policy of continuous advancements in development. For this reason specifications may be changed without notice

Memory backup function

Please note that the following contents will be erased if this unit is not turned ON for approximately 3 days.

- POWER status (ON or OFF)
- Input setting
- Volume level
- Receiving band
- Frequency
- Preset stations

Specifications other countries

Caution: Read this page carefully to ensure safe operation.

KR-V5580 (En)

Audio section

Rated power output at the STEREO operation
1 kHz, 10 % THD at 8 Ω 100 W + 100 W
(DIN/IEC) from 63 Hz to 12,500 Hz,
0.7 % T.H.D., at 8 Ω 80 W + 80 W

Power output at the Surround operation
Front (1 kHz, 0.7 % T.H.D. at 8 Ω) 50 W + 50 W
Center (1 kHz, 0.7 % T.H.D. at 8 Ω) 50 W
Rear (1 kHz, 0.7 % T.H.D. at 8 Ω) 15 W + 15 W

Front (1 kHz, 10 % T.H.D. at 8 Ω) 75 W + 75 W
Center (1 kHz, 10 % T.H.D. at 8 Ω) 75 W
Rear (1 kHz, 10 % T.H.D. at 8 Ω) 23 W + 23 W

Total harmonic distortion (1 kHz, 8 Ω) 0.03 % at 50 W
Signal to noise ratio (IHF'A)
PHONO (MM) 74 dB
CD 100 dB

Input sensitivity / impedance
PHONO (MM) 2.5 mV / 47 kΩ
CD, TAPE, VIDEO 200 mV / 47 kΩ

Tone controls
BASS ± 10 dB (at 100 Hz)
TREBLE ± 10 dB (at 10 kHz)
Loudness control at - 30 dB VOLUME level
..... + 8 dB (100 Hz)

Video section

VIDEO inputs / outputs (Composite) 1 Vp-p / 75 Ω



KENWOOD follows a policy of continuous advancements in development. For this reason specifications may be changed without notice.

For the U.S.A.

FCC WARNING

This equipment may generate or use radio frequency energy. Changes or modifications to this equipment may cause harmful interference unless the modifications are expressly approved in the instruction manual. The user could lose the authority to operate this equipment if an unauthorized change or modification is made.

NOTE:

This equipment has been tested and found to comply with the limits for a Class B digital device, pursuant to Part 15 of the FCC Rules. These limits are designed to provide reasonable protection against harmful interference in a residential installation. This equipment may cause harmful interference to radio communications, if it is not installed and used in accordance with the instructions. However, there is no guarantee that interference will not occur in a particular installation. If this equipment does cause harmful interference to radio or television reception, which can be determined by turning the equipment off and on, the user is encouraged to try to correct the interference by one or more of the following measures:

- Reorient or relocate the receiving antenna.
- Increase the separation between the equipment and receiver.
- Connect the equipment into an outlet on a circuit different from that to which the receiver is connected.
- Consult the dealer or an experienced radio / TV technician for help.

For the U.S.A.

Note to CATV system installer:

This reminder is provided to call the CATV system installer's attention to Article 820-40 of the NEC that provides guidelines for proper grounding and, in particular, specifies that the cable ground shall be connected to the grounding system of the building, as close to the point of cable entry as practical.

FM Tuner section

Tuning frequency range 87.5 MHz-108 MHz
Usable sensitivity (IHF) 13.2 dBf (1.2 μV at 75 Ω)
50 dB quieting sensitivity
STEREO 41.2 dBf (32 μV at 75 Ω)

Total harmonic distortion at 1 kHz
MONO 0.6 %
STEREO 0.7 %

Signal to noise ratio at 65 dBf (IHF)
MONO 75 dB
STEREO 68 dB

Selectivity (IHF ± 400 kHz) 50 dB
Stereo separation (IHF at 1 kHz) 40 dB

AM Tuner section

Tuning frequency range
9 kHz 531 kHz ~ 1,602 kHz
10 kHz 530 kHz ~ 1,610 kHz

Usable sensitivity 12 μV / (500 μV / m)
Total harmonic distortion 0.7 %
Signal to noise ratio 48 dB
Selectivity 30 dB

General

Power consumption 220 W
AC outlet
SWITCHED 2: (total 150 W max.)

Dimensions W: 440 mm
H: 143 mm
D: 380 mm

Weight (net) 9.1 kg

KENWOOD

For your records

Record the serial number, found on the back of the unit, in the spaces designated on the warranty card, and in the space provided below. Refer to the model and serial numbers whenever you call upon your dealer for information or service on this product.